

## ADJUSTING UNIT VEN 45X90 S WITH CLAMPING DEVICE AT TOP

Code: 280187/1

Linear unit VEN 45x90 S with top clamping unit allows easy and precise adjustment of conveyors, feeders, and other equipment.

[Link to the product →](#)

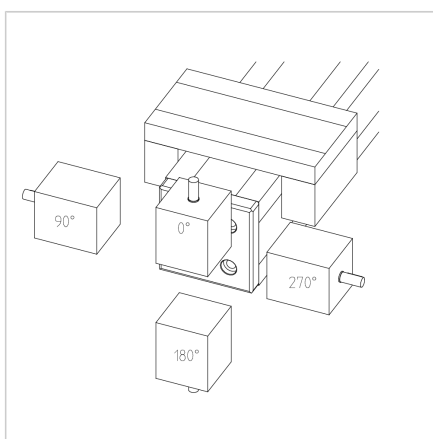
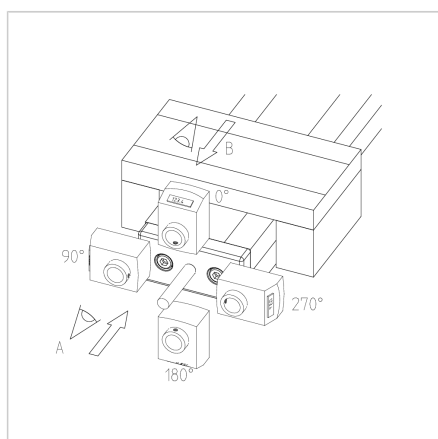
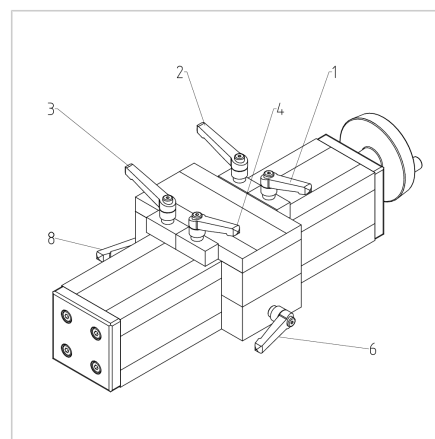
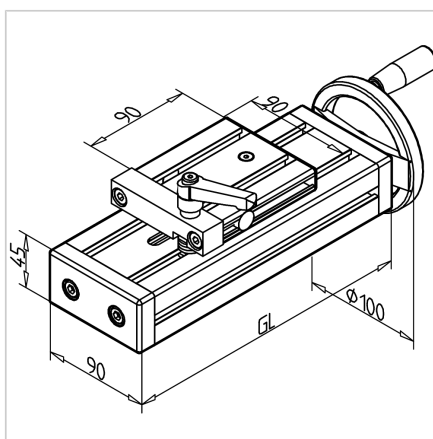

### Technical data/items supplied

- Aluminium, anodized E6/EV1
- Slide plate of profile 19 x 90
- Spindle 16 x 4
- Basic length (GL) 140 mm (at 0 mm stroke)
- **Please indicate desired length of stroke**

### Applications

- Adjustment of conveyors
- Adjustment of feeders
- Adjustable devices

### Other versions

- Slide plate made of profile 32 x 180
- Deviating wagon length
- Digital display
- Angular drive
- Longer length possible if needed