

CANTAINER BLACK ESD COMPLETE WITH CAVITY FOR GOOD GRIP, SEPARATOR AND COVER

Code: 320870/5

ESD boxes resist industrial use and impacts, providing safe storage and flexible repositioning for electronics.

[Link to the product →](#)

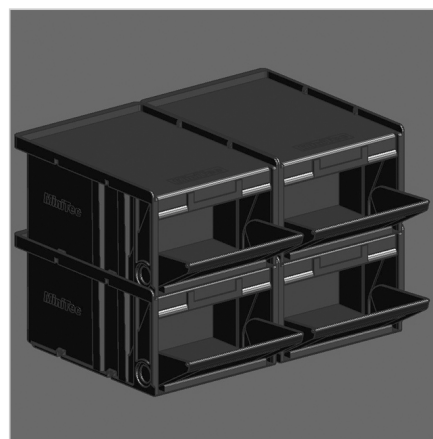
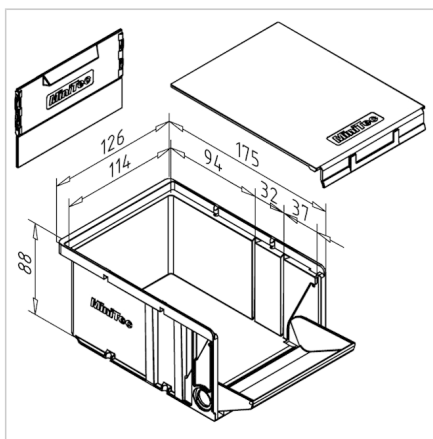

Technical data/items supplied

- Dimension: 175x126x88 mm
- Imposed load: 50 kg
- Load due to contents: 5 kg
- Temperature resistance: -20°C to +90°C
- Material: Polypropylene, polystyrene
- Weight = 0.208 kg/piece

Applications

- Full use of storage rack due to retractable tray
- Ergonomically optimised tray makes the contents easier to remove
- Transparent cover protects against dirt and mixing of the parts
- Cover as protection against unintentional opening or loss of parts
- Transparent metering disc: easy identification of remaining quantities
- Metering disc prevents uncontrolled trickling out of small parts
- Secure stacking due to locating pins and eyes
- Labelling on both sides
- Retaining device on the side of the box