

COMPARTMENT FLOOR CABINET 150/150 ESD

Code: 320810/6

Conductive workbench drawer 150/150 protects sensitive electronic components from static electricity and provides organized tool storage.

[Link to the product →](#)

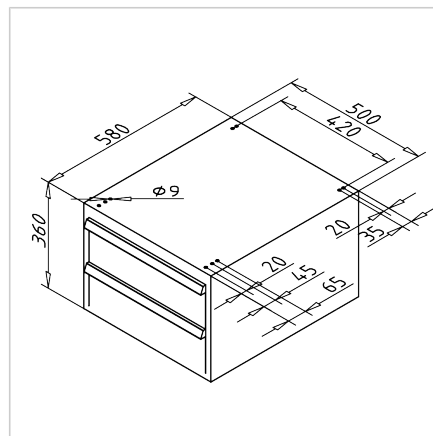

Technical data/items supplied

- Steel, lacquered
- With fastening material steel, zinc plated
- Color:
 - body and drawer light grey RAL 7035
 - conductive
- Cylinder lock with 2 keys, center locking for all drawers
- Individual drawer locking
- 2 drawers, H = 150 mm, with perforated bottom
- Large handle bar with label adapter
- Can be pulled out up to 80 %
- Drawer inside W = 425 mm T = 550 mm, effective height = H-10 mm
- Max. load capacity per compartment 35kg
- Max. load capacity per cabinet: 200 kg
- Weight = 22.570 kg/piece

Assembly

- Use fastening kit to fasten to base frame
- Alternatively attach with mounting set **part no. 320806/0** to strut profiles of the base frame