

DRILLING JIG FOR MITRE-CONNECTOR N 30 (GVB-N30)

Code: 261056/0

Drilling jig for mitre connector N30 provides precise hole drilling, easy positioning, and quick preparation of aluminum profiles for assembly.

[Link to the product →](#)

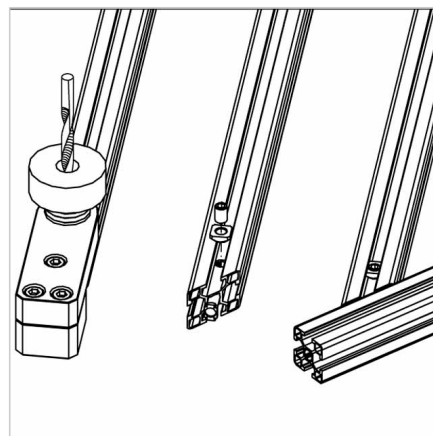
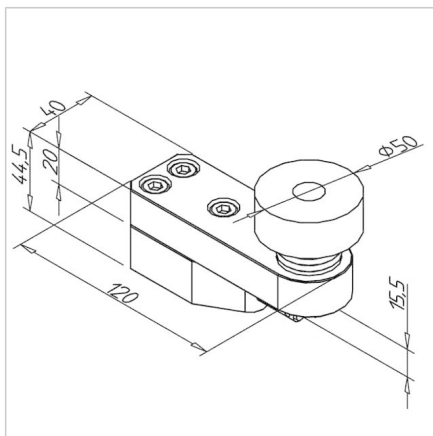
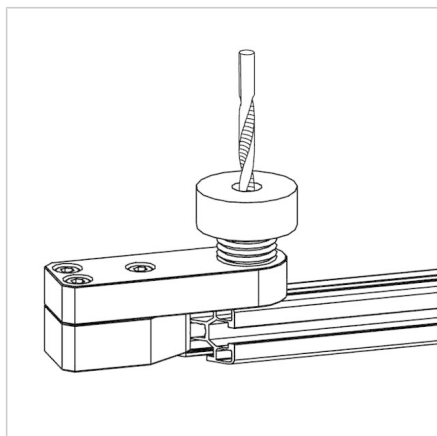

Technical data/items supplied

- Centering pin: steel
- Fixation screw: Plastic with steel bore bushing
- Weight = 0.477 kg/piece

Applications

- Positioning of bore for set screw of mitre connector N30 in relation to mitre angle
- Fitting for all profiles of profile series 30

Assembly

- Cut profile in desired angle
- Insert the plug gauge until the stop, tighten the plastic locking screw
- Insert bore $\varnothing 8.0$ mm into profile at corresponding depth through drill bush
- Insert a drilling jig for mitre connector N30 **part no. 210945/0**