

DRIVE DRUM 45ST, KIT MOTOR ATTACHMENT 45 L (BELT WIDTH) = MM

Code: 295022/0

[Link to the product →](#)

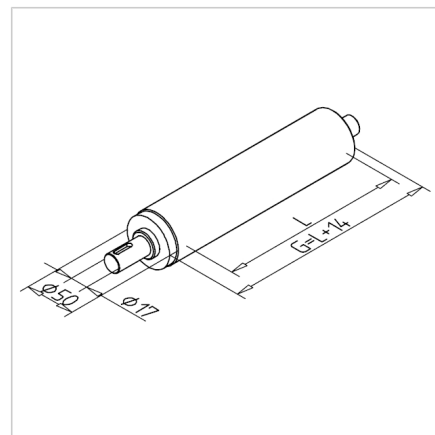
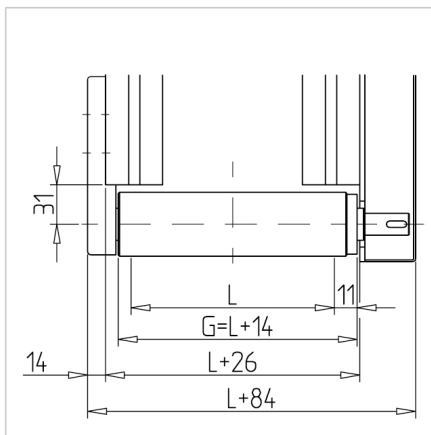

Technical data/items supplied

- Stainless steel
- Turned round
- Shaft journal Ø 17 mm, drive side machined for installing the chain wheel from kit engine
- **Please specify dimension L (belt width)**
- **Attention: L is not the external dimensions(G) of the conveyor Ø50**
- Weight = (basic weight) approx. 0.3 kg
- Extra weight = 1.541 kg/100mm belt width

Applications

- Can only be used with the MiniTec belt conveyor kit 45
- On request we can deliver the conveyor with mounted ball bearings. The bearings are gentle on material, hot pressed. Please additionally following **part no.** 21.0900/0 order.

Assembly

- Insert the belt driving cylinder in the bearing housing on the motor side
- On the opposite side conveyor bearing e.g. **part no.** 210993/0 mount
- The drum is sealed between the inner rings of the pendulums