

## DRIVE DRUM 45ST L , PLUG-ON MOTOR D20 L (BELT WIDTH) = MM

Code: 295042/0

[Link to the product →](#)

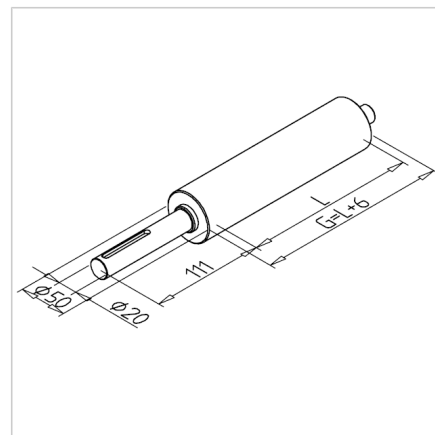
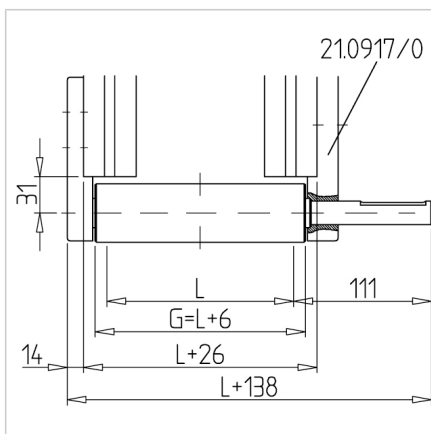

### Technical data/items supplied

- Stainless steel
- Turned round
- Shaft journal  $\varnothing 20$  mm, drive side machined for installing the chain wheel from kit engine
- **Please specify dimension L (belt width)**
- **Attention: L is not the external dimensions(G) of the conveyor  $\varnothing 50$**
- Weight = (basic weight) approx. 0.3 kg
- Extra weight = 1.541 kg/100mm belt width

### Applications

- MiniTec belt conveyor systems DSGM with torque support Wa 20 and WA 30
- Suitable for MiniTec motor with torque arm of series 90
- On request we can deliver the conveyor with mounted ball bearings. The bearings are gentle on material, hot pressed. Please additionally following **part no.** 21.0900/0 order.

### Assembly

- Insert the belt driving cylinder in the conveyor bearing for plug-on motor 45-20 **Part-N° 210917/0**
- On the opposite side conveyor bearing e.g. **part no. 210993/0** mount