

FASTENING KIT LRE INOX

Code: 280022/1

LRE H fastening kit for easy and reliable mounting of components on linear guides.

[Link to the product →](#)

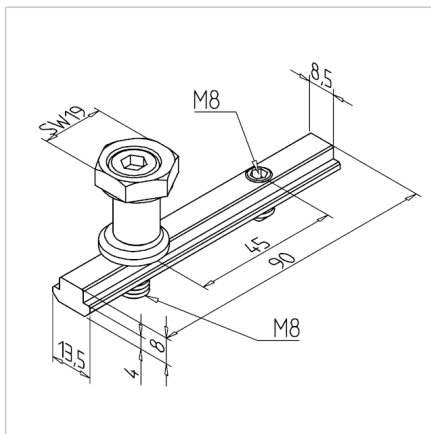
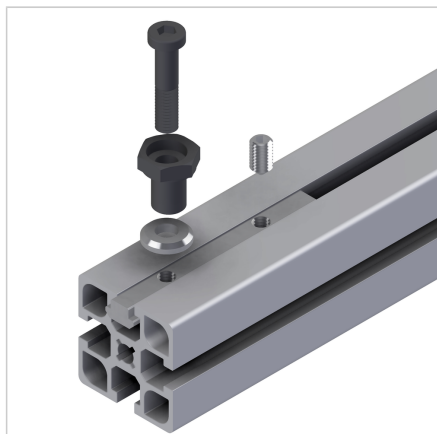

Technical data/items supplied

- Stainless steel
- T-slot stainless with set screw
- Eccentric bushing, stainless
- Bolt M8 concentric, stainless
- Spacer 3,5 mm stainless
- Weight = 0.100 kg/piece

Applications

- MiniTec linear guides LR 12
- Concentric attachment of ball bearings LR 12

Assembly

- Fit the clamping strip similar to LRK
- Insert bolt M8 into the eccentric bushing pre-installed in the bearing bore and place the spacer washer. Pre-tighten the bolt with the Allen wrench SW4 onto the clamping bar
- Adjust bush with ring spanner width 19 mm (turn for freedom from clearance with 0,9 - 1 Nm) and fix bolt
- Recommended torque: 25 Nm