

FLOOR ANGLE BRACKET

Code: 211112/0

Angle bracket for floor fastening enables secure attachment of aluminium constructions to the floor, providing additional stability and safety.

[Link to the product →](#)

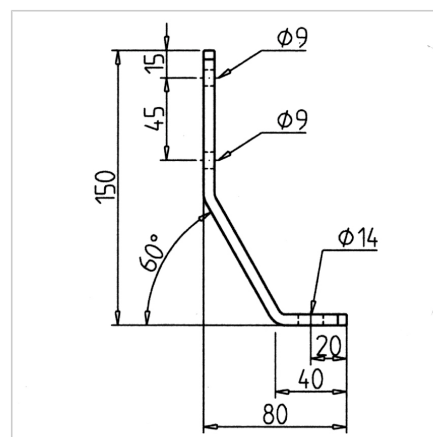
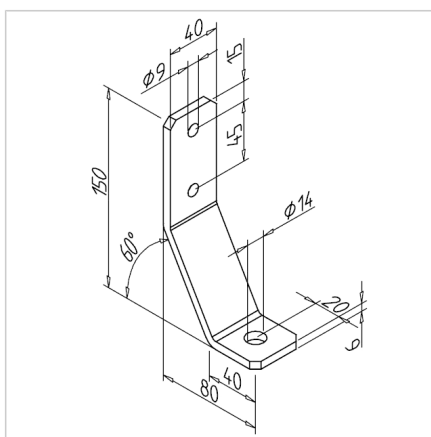

Technical data/items supplied

- Steel, powder-coated, grey
- With fastening material steel, zinc plated
- Without dowels
- Weight = 0.389 kg/piece

Applications

- Securing and fastening of constructions on floor or wall

Assembly

- On profile side with cylinder screws M8 x 20, SW5
- Bottom side with high performance anchor 12 **part no. 211115/0**
- Also suitable for subsequent mounting