

HINGED FOOT M10 D100 WITH FIXATION BORES L = 122 MM

Code: 211846/0

Adjustable foot M10 D100 with multiple mounting holes for stable and flexible support of aluminum structures.

[Link to the product →](#)

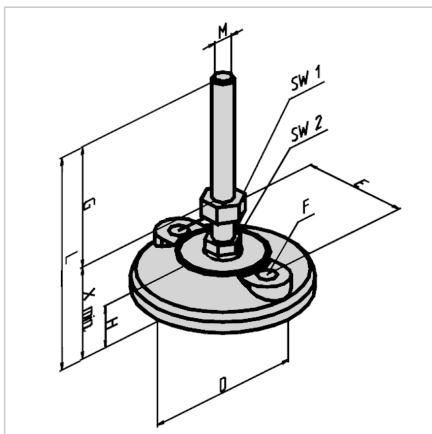

Technical data/items supplied

- Plate PA, grey
- Anti-slip license NBR, black
- Spindle steel, galvanized
- Lock nut steel, galvanized
- Angular compensation up to 15°
- Thread M10
Plate $\varnothing = 100$ mm
Dimension G = 82 mm
Dimension X = 40 mm
SW1 = 17 mm
SW2 = 14 mm
Dimension L = 122 mm
Dimension E = 74 mm
 $\varnothing F = 9$ mm
Load capacity max. 1000 kg
- Weight = 0.179 kg/piece

Applications

- Height adjustable constructions of all kinds
- Protective equipment, tables, showcases
- Conveyors, system workstations

Assembly

- Directly in the central bore of the profile (can be drilled with thread up to M12)
- Larger threads in connection with connection plate
- For threads larger than M12, the hinged feet must be mounted in conjunction with the connection plate
- For profiles 45 x 90 und 90 x 90 a base and transport plate is required, if the feet are to be positioned centrally.