

LINEAR MODULE LMS 90 K16X16 S1

Code: 281000/2

Linear module LMS 90 K16x16 S1 delivers precise and reliable linear motion, suitable for a wide range of industrial applications.

[Link to the product →](#)

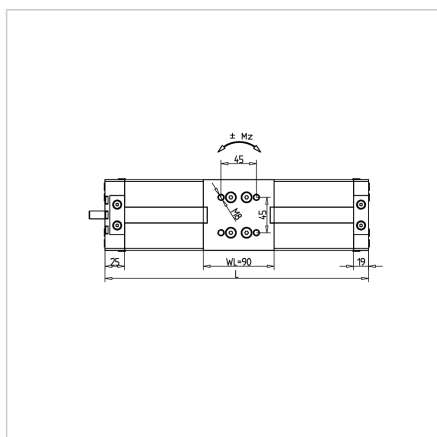
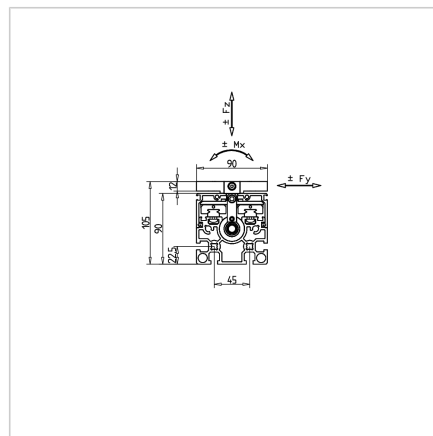
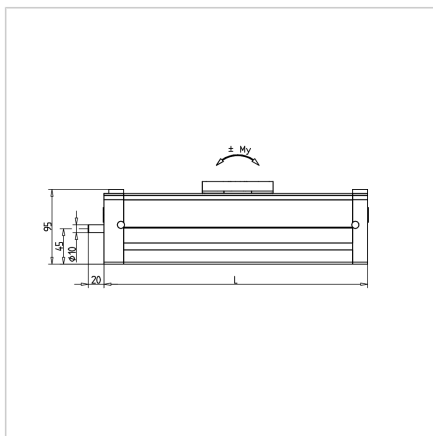

Technical data/items supplied

- 2 rail guides with each 1 linear slide Dim. 15
- Stroke = L- 140 mm
- Stroke up to 2845 mm
- Ball screw with tolerance class T7, right
- High load-carrying rail slide with continuous lubrication
- Load rating:
Cdyn: 7,620 N
Cstat: 11,180 N
- Allowable static tilting moment:
Mx: 54 Nm
My: 54 Nm
Mz: 54 Nm

Assembly

- Simple mounting of external switches on lateral profile grooves