

LINEAR MODULE LMS 90 K16x4 G

Code: 281001/0

Linear module LMS 90 K16x4 G enables precise and reliable linear motion for industrial use.

[Link to the product →](#)

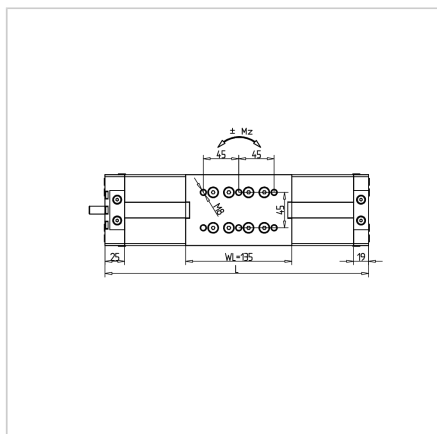
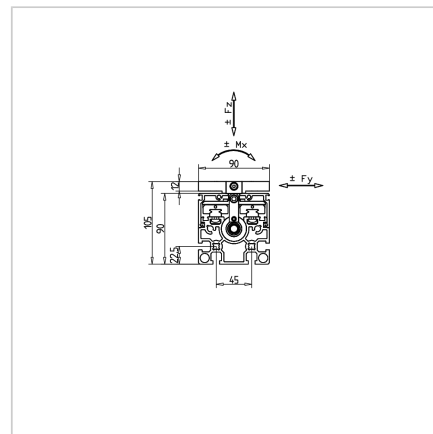
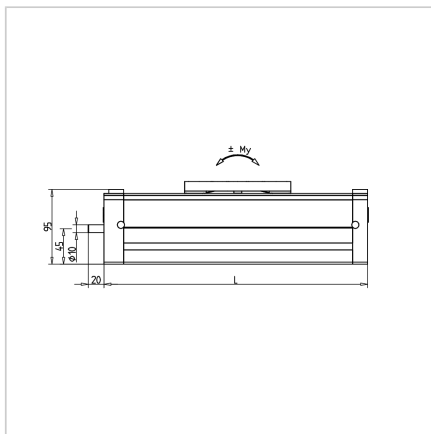

Technical data/items supplied

- Aluminium slides, precision-machined at all sides
- Stroke = L- 185 mm
- Travel to 1800mm
- Optional design with feather key or adapter plate machined according to motor specification
- Trapezoidal screw drive 16x4, optional right pre-tensioned with increased precision
- Load rating:
Cdyn: 2,800 N
Cstat: 2,800 N
- Allowable static tilting moment:
Mx: 22 Nm
My: 22 Nm
Mz: 22 Nm

Applications

- Plastic sliding guides for very economical implementations,
2 Sliding guides with each 2 linear slides
Dim. 15
- Special grooves for external mounting of position sensors

Assembly

- Simple mounting of external switches on lateral profile grooves