

## MOTOR MOUNTING KIT 45 D20

Code: 295031/0

[Link to the product →](#)

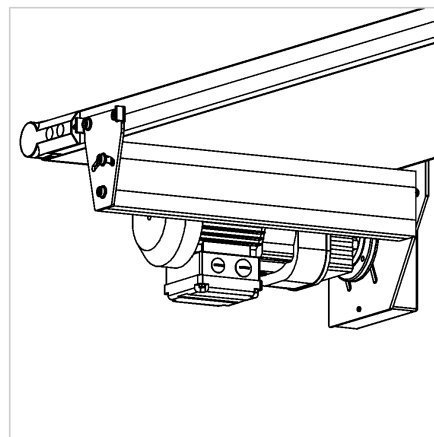
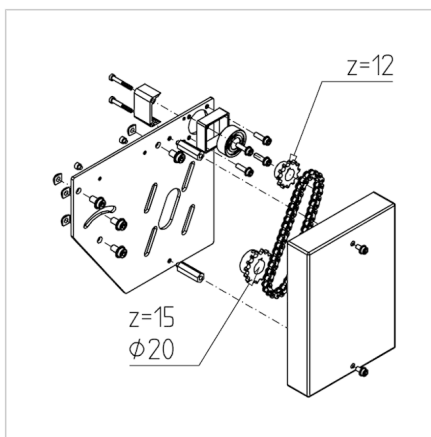

### Technical data/items supplied

- With fastening material steel, zinc plated
- Motor plate and cover, steel, powder coated, grey
- Bearing housing with self-aligning bearing
- 2 sprockets with drive chain, 1 sprocket drilled for motor shaft diameter  $\varnothing 20$  mm
- Weight = 3.344 kg/piece

### Applications

- Belt-conveyors made of MiniTec aluminium profiles
- Suitable for mounting spur gear motors with flange diameter  $\varnothing 120$  mm
- Fitting belt driving cylinder part no. 295022/0 and belt tensioning cylinder part no. [210994/1](#)

### Assembly

- Screw the flange plate to the base frame, install the bearing housing with the self-aligning bearing
- Insert belt driving cylinder, on the opposite side, eg. conveyor bearing part no. 21.0993/0 use
- Mount engine, install chain wheels and tighten the chain
- Fit the cover
- Please note our design suggestion if the conveyor belt is to be used without base frame