

MOTOR MOUNTING KIT 90 - D20

Code: 295060/0

[Link to the product →](#)

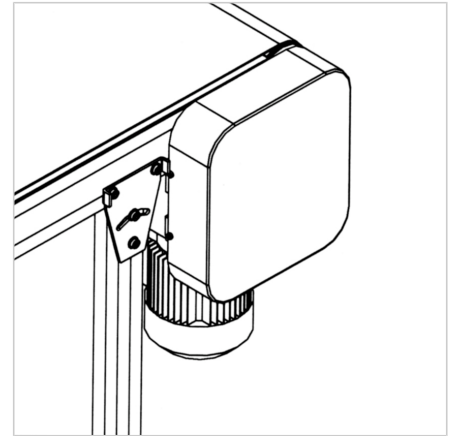
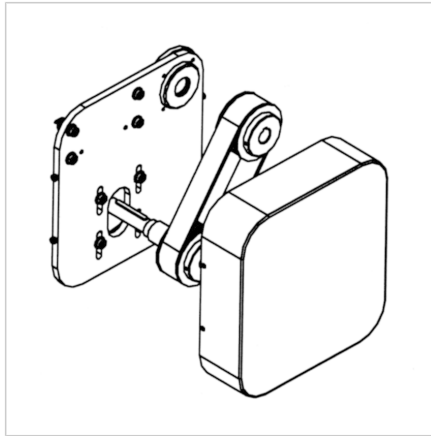
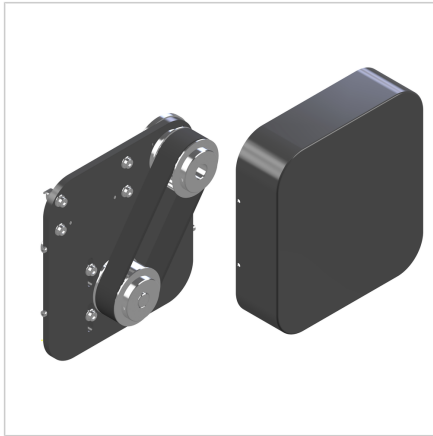

Technical data/items supplied

- Motor plate and cover, steel, powder coated, grey
- Bearing housing with self-aligning bearing
- Belt driving cylinder \varnothing 20 mm
- Timing belt 32 AT 10
- Fastening kit
- Weight = 5.973 kg/piece

Applications

- Belt-conveyors made of MiniTec aluminium profiles 90
- Suitable for mounting spur gear motors with hollow shaft \varnothing 20 mm flange \varnothing 120 mm

Assembly

- Screw the flange plate to the base frame, install the bearing housing with the self-aligning bearing
- Install and tension the motor and timing belt drive
- Insert belt driving cylinder, use conveyor bearing at opposite side part no. 210985/0
- Fit the cover