

MULTIBLOCK GD MIT GLEITMUTTER OHNE FEDERBLECH

Code: 211355/6

[Link to the product →](#)

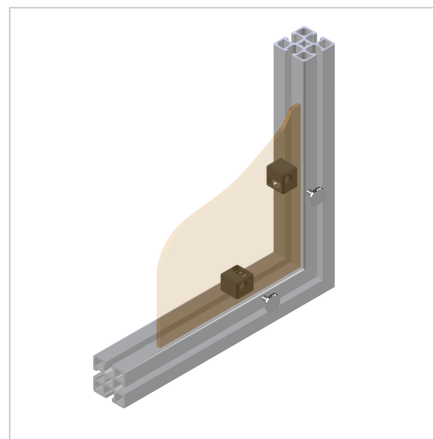
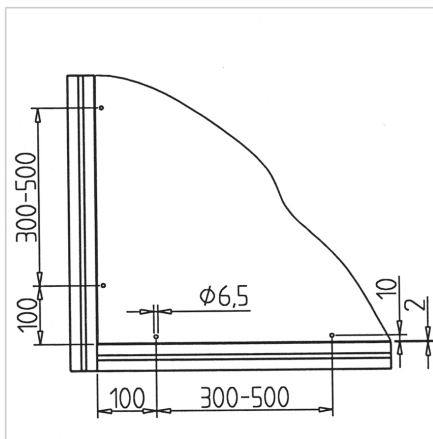
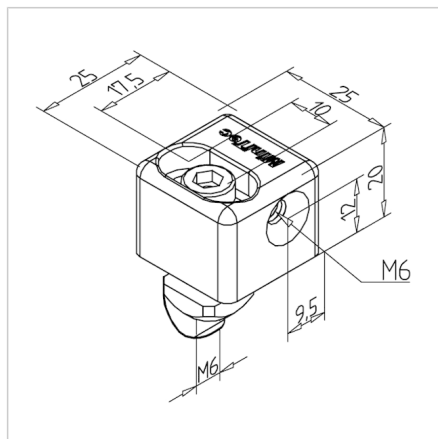

Technical data/items supplied

- Aluminium, Pressure die-casting, powder-coated
- With fastening material steel, zinc plated
- Without pan head screw
- Weight = 0.035 kg/piece

Applications

- Retrofitting surface elements and attachments
- Plate thickness of 5 to 15 mm can be continuously flush fit

Assembly

- For all profile grooves
- Fastening surface elements or components with screw M6 or flat head screw
- Bore for fixation screws $\phi 6.5$ mm, edge distance 10 mm