

## SLIDE LW 45

Code: 280091/0

LW 45 linear slide, designed for high precision and quiet operation of linear guides in industrial applications.

[Link to the product →](#)

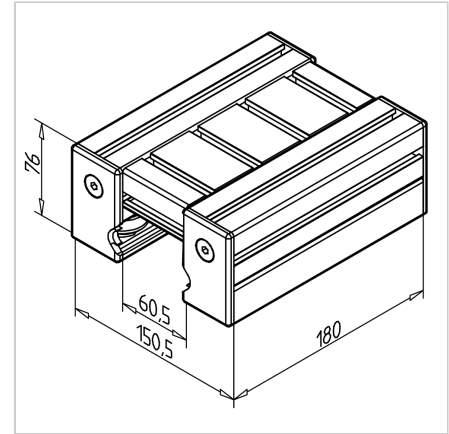
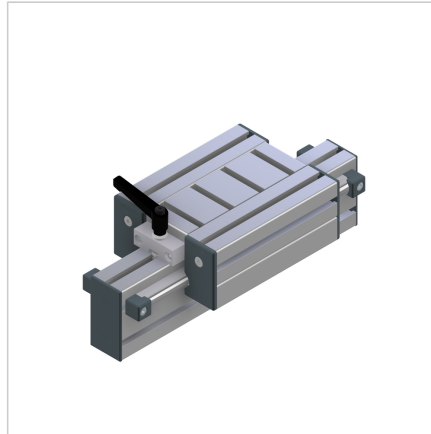

### Technical data/items supplied

- Aluminium, anodized E6/EV1
- Fully mounted carriage
- 2 concentric and 2 eccentric bearing units
- End caps LR and 2 cover profiles LR
- Stainless version **part no. 280091/3**
- Weight = 2.260 kg/piece

### Applications

- 1- or multi-axis guides
- Linear robots
- Handling devices
- Measuring devices
- For rails 45, 45 x 90 H, 45 x 180 H and 135 H

### Assembly

- Assemble slide on rail 45 or 45 x 90 H, adjust clearance with eccentric bush
- Install the cover and lubrication system
- Slide clamping unit **part no. 280270/0**