

## SLIDE LWN 32X45-45 WITH CLAMPING DEVICE AT TOP

Code: 280192/1

Linear carriage LWN 32 x 45 series 45 with top clamping unit allows precise adjustment and reliable locking in aluminum profile constructions.

[Link to the product →](#)

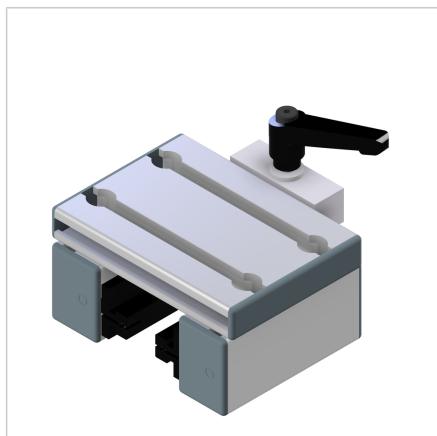

### Technical data/items supplied

- Aluminium, powder-coated
- Fully mounted carriage
- 2 slide rails LN
- End caps
- Clearance adjusted
- Weight = 0.877 kg/piece

### Applications

- Simple linear guides
- Slide units

### Other versions

- With slide clamping device lateral **part no. 280192/2**
- Different slide lengths