

SLIDE LWN 32X45-90 WITH CLAMPING DEVICE AT TOP

Code: 280193/1

Linear carriage LWN 32 x 45 series 90 with top clamping unit allows precise adjustment and reliable locking in aluminum profile constructions.

[Link to the product →](#)

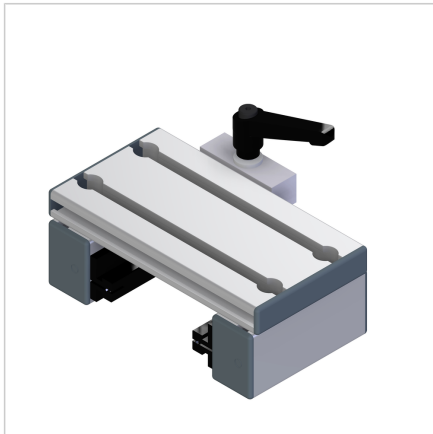

Technical data/items supplied

- Aluminium, anodized E6/EV1
- Fully mounted carriage
- 2 slide rails LN
- End caps
- Clearance adjusted
- Weight = 0.961 kg/piece

Applications

- Simple linear guides
- Slide units

Other versions

- With slide clamping device lateral **part no. 280193/2**
- Different slide lengths